



# San Diego Unified School District

PHYSICAL PLANT OPERATIONS CENTER ANNEX  
4860 Ruffner Street, San Diego, CA 92111-1522

(858) 496-1902  
Fax: (858) 496-1953

Graham Champion  
Labor Compliance and  
Construction Contracts Supervisor

September 11, 2020

Mr. Stephen Thompson  
Solpac Construction, Inc.  
dba Soltek Pacific Construction Company  
2424 Congress Street  
San Diego, CA 92110

Dear Mr. Thompson:

**Subject: CZ-19-0673-42 – Design Build Construction of Heating, Ventilation, and Air Conditioning (HVAC) at Multiple Sites – Package A (SDUSD Project # 92790071.1)**

**Notice to Proceed: No. 12R2– HVAC Construction at Torrey Pines Elementary School**

This letter constitutes your *revised* notice to proceed with HVAC work at Torrey Pines ES per your proposal with the scope of work breakdown to Les Osterberger dated July 30, 2020, for a reduction of \$783.47, a total not-to-exceed amount of \$2,777,470.93.

|                                       |   |
|---------------------------------------|---|
| NTP 12R2 Torrey Pines ES Construction | <del>\$2,543,111.00</del> <u>\$2,542,327.53</u> |
| NTP 12R2 Torrey Pines ES Contingency  | \$235,143.40                                    |

Work shall begin on December 23, 2019, and be completed by May 27, 2020.

Please refer to this NTP number on all your correspondence and invoices.

Original invoice should be sent to:

San Diego Unified School District  
PPO Center, Attn: Catherine Bendixen  
4860 Ruffner Street  
San Diego, CA 92111

Please call your construction manager if you have any questions regarding this NTP. Invoicing inquiries should be directed to Catherine Bendixen at (858) 637-6246.

Sincerely,

  
Graham Champion  
Labor Compliance and Construction Contracts Supervisor

GC:cp

Attachment

C: D. Nestor, L. Osterberger, K. Shroyer, R. Musin, PSA



2424 Congress Street  
San Diego CA, 92110  
P 619.296.6247 | F 619.296.7109  
Contractor License #886641 | EOE

### CONTINGENCY ADJUSTMENT PROPOSAL

**Attention:** Mr. Les Osterberger **Date:** 7/30/2020

**Project:** SDUSD HVAC Design Bulld Projects **Construction NTP Adjustment No:** Torrey Pines ES 001  
**School:** Torrey Pines ES

**Contract No:** CZ-19-0673-42 **Subject:** Credit for the Deletion of Gas Seismic Valve per CCD #014A  
**Reference:** CCD #014A

|   |
|---|
| <p><b>Description of work to be performed:</b></p> <p>This Construction NTP Adjustment is to compensate the owner for all credits associated with CCD #014A which directed the contractor to delete Sheet P0.1's general note #10 and void general note #10's requirement to install seismic gas shut off valves. It also directed the Contractor that the installation of site/building gas service and site gas distribution are not in this project's scope of work.</p> |
|---|

**Adjustment Total:** \$ (783.47) **Additional Time to be Added to Contract:** 0 Days **Estimated Qty:** 1 LS

Please see attached breakdown of cost.

Approved: \_\_\_\_\_  
SDUSD Construction Manager Date

Please do not hesitate to contact me with any questions or comments regarding this matter.  
Best regards,

Soltek Pacific Construction  
Mark Hofmann  
Sr. Project Manager

CC: File, Field, Subcontractor

**SOLTEK PACIFIC**

CZ-19-0673-42

Subject: **Credit for the Deletion of Gas Seismic Valve per CCD #014A**

| <b>PAYMENT -- EXTRA, ADDITIONAL, OR DELETED WORK</b> |   | <b>Extra/Credit</b> |
|--|---|---------------------|
| 1.   | <u>General Contractor Material</u><br>a. Attach itemized quantity and unit cost plus sales tax<br>b. Include information where derived, i.e., "Means Building Construction Cost Data" or other source mutually agreed to by all parties.  | \$ -                |
| 2.   | <u>General Contractor Labor</u><br>Attach itemized hours and rates per certified payrolls and prevailing wage chart. Rates shall only include a maximum of 15% for payroll burden plus actual costs for Workers' Compensation Insurance. Payment for extra supervision will be paid when extra Work is done in a time period other than normal Working hours. | \$ -                |
| 3.   | <b>Subtotal - (Item #1 plus Item #2)</b>  | \$ -                |
| 4.   | <u>General Contractor's overhead, profit, supervision, bond fees</u> A maximum aggregate total of 16% of Item #3.<br>This item is not allowed on Extended Overhead  | \$ -                |
| 5.   | <b>Total General Contractor (Item #3 plus Item #4)</b>  | \$ -                |
| 6.   | <u>Subcontractor Material</u><br>a. Attach itemized quantity and unit cost plus sales tax<br>b. Include information where derived, i.e., "Means Building Construction Cost Data" or other source mutually agreed to by all parties.   | \$ -                |
| 7.   | <u>Subcontractor Labor</u><br>Attach itemized hours and rates per certified payrolls and prevailing wage chart. Rates shall only include a maximum of 15% for payroll burden plus actual costs for Workers' Compensation Insurance. Payment for extra supervision will be paid when extra Work is done in a time period other than normal Working hours.      | \$ -                |
| 8.   | <b>Subtotal - (Items #6 and #7)</b>   | \$ (783.47)         |
| 9.   | <u>General Contractors' overhead, supervision, bond fees and profit for Subcontractor Work</u> (maximum aggregate total of 11% of Item #8)<br><br>This item is not allowed on Extended Overhead   |                     |
| 10.  | <u>Subcontractor's Overhead and Profit</u><br>Maximum aggregate total of 15% of Item #8. Not to be included for Work provided by General Contractor. No Sub-Tier markups allowed. Attach signed Subcontractor documentation on Subcontractor letterhead.  | \$ -                |
| 11.  | <b>Subtotal - (Items #9 &amp; #10)</b>  | \$ -                |
| <b>TOTAL (Item #5 plus Item #8 plus Item #11)</b>    |   | \$ (783.47)         |

EXTRA OR CREDIT CHANGE ORDERS WILL NOT BE CONSIDERED UNLESS THIS EXHIBIT IS COMPLETELY FILLED IN WITH ALL ADDS AND DEDUCTS ACCOUNTED FOR ALONG WITH APPROPRIATE BACKUP DOCUMENTATION.

Cost summaries, breakdowns, back-up or requests shall not be based, in whole or in part, upon any methodology (such as "total cost", "modified total cost" or "Eichleay" formallitic methodologies) that purports to calculate or estimate additional costs of performance of the extra, additional or disputed work (including without limitation the additional costs of delay, disruption, interference, hindrance, unabsorbed overhead or other impacts) and the cumulative impact of each extra, additional or deleted work on other parts of the Work.

**Construction NTP Adjustment Request Estimate**  
**Contract No. CZ-19-0673-42**

**SDUSD HVAC Design Build Projects**  
**Torrey Pines ES**

|                                       |                     |  |                        |
|---------------------------------------|---------------------|--|------------------------|
| <b>Construction NTP Adjustment #:</b> | Torrey Pines ES 001 | <b>Subject:</b> Credit for the Deletion of Gas Seismic Valve per CCD #014A | <b>Date:</b> 7/30/2020 |
|---------------------------------------|---------------------|--|------------------------|

| Items of Work for Subcontractor                            | Quan | Unit | Material  |            | Labor     |            | Subcontract |       | Equipment   |       |
|--|------|------|-----------|------------|-----------|------------|-------------|-------|-------------|-------|
|  |      |      | Unit Cost | Total Cost | Unit Cost | Total Cost | Unit Cost   | Total | Unit Cost   | Total |
| Credit for the Deletion of Gas Seismic Valve per CCD #014A |      |      |           |            |           |            | \$ (783.47) |       |             |       |
|  |      |      |           |            |           |            |             |       |             |       |
|  |      |      |           |            |           |            |             |       |             |       |
|  |      |      |           |            |           |            |             |       |             |       |
|  |      |      |           |            |           |            |             |       |             |       |
|  |      |      |           |            |           |            |             |       |             |       |
|  |      |      |           |            |           |            |             |       |             |       |
|  |      |      |           |            |           |            |             |       |             |       |
|  |      |      |           |            |           |            |             |       |             |       |
|  |      |      |           |            |           |            |             |       |             |       |
|  |      |      |           |            |           |            |             |       |             |       |
|  |      |      |           |            |           |            |             |       |             |       |
|  |      |      |           |            |           |            |             |       |             |       |
|  |      |      |           |            |           |            |             |       |             |       |
|  |      |      |           |            |           |            |             |       |             |       |
|  |      |      |           |            |           |            |             |       |             |       |
|  |      |      |           |            |           |            |             |       |             |       |
|  |      |      |           |            |           |            |             |       |             |       |
|  |      |      |           |            |           |            |             |       |             |       |
|  |      |      |           |            |           |            |             |       |             |       |
| <b>Direct Subcontractor Totals</b>                         |      |      |           | \$ -       |           |            | \$ -        |       | \$ (783.47) | \$ -  |

| Items of Work by General Contractor    | Quan | Unit | Material  |            | Labor     |            | Equipment |       |
|--|------|------|-----------|------------|-----------|------------|-----------|-------|
|  |      |      | Unit Cost | Total Cost | Unit Cost | Total Cost | Unit Cost | Total |
|  |      |      |           |            |           |            |           |       |
|  |      |      |           |            |           |            |           |       |
|  |      |      |           |            |           |            |           |       |
|  |      |      |           |            |           |            |           |       |
|  |      |      |           |            |           |            |           |       |
|  |      |      |           |            |           |            |           |       |
|  |      |      |           |            |           |            |           |       |
|  |      |      |           |            |           |            |           |       |
|  |      |      |           |            |           |            |           |       |
|  |      |      |           |            |           |            |           |       |
|  |      |      |           |            |           |            |           |       |
|  |      |      |           |            |           |            |           |       |
|  |      |      |           |            |           |            |           |       |
|  |      |      |           |            |           |            |           |       |
|  |      |      |           |            |           |            |           |       |
|  |      |      |           |            |           |            |           |       |
|  |      |      |           |            |           |            |           |       |
|  |      |      |           |            |           |            |           |       |
|  |      |      |           |            |           |            |           |       |
|  |      |      |           |            |           |            |           |       |
| <b>Direct Prime Contractors Totals</b> |      |      |           | \$ -       |           |            | \$ -      | \$ -  |



## CONST. CHANGE DIRECTIVE-Type A

SAN DIEGO UNIFIED SCHOOL DISTRICT Facilities Planning & Construction / Physical Plant Operations  
4860 Ruffner St San Diego, CA 92111-1522

**Title:** Delete Gas Seismic Valve  
**Project:** Torrey Pines HVAC Phase 2  
**From:** San Diego Unified School District  
**To:** Soltek Pacific

**Change Number:** 014  
**Date:** 06/11/2020

**Remarks:**

Delete Sheet P0.1's General Note #10. Void General Note #10's requirement to install seismic gas shut off valve. Installation of Site / Building Gas Service and installation of Site Gas Distribution are not in this project's scope of work.

**Justification:**

Design Build ? VE Coordination Item



140

# APPLICATION FOR SUBMITTAL OF POST-APPROVAL DOCUMENT

This application is for submittal of documents, after the initial approval of the project (post-approval documents), that require Division of the State Architect (DSA) review and approval. This form shall be completed by the Design Professional in General Responsible Charge of the project, in accordance with California Code of Regulations, Title 24, Part 1, Sections 4-317, 4-323 and 4-338 and in compliance with DSA IR A-6: Construction Change Document Submittal and Approval Process.

DSA documents referenced within this form are available on the [DSA Forms](#) or [DSA Publications](#) webpages.

|   |                  |  |   |  |
|---|------------------|--|---|--|
| <b>1. SUBMITTAL TYPE: (Is this a resubmittal? Yes <input checked="" type="checkbox"/> No <input type="checkbox"/>)</b>  |                  |  |   |  |
| Deferred Submittal  | Addendum Number: | Revision Number: 2   | CCD Number: 014   | Category A <input checked="" type="checkbox"/> or B <input type="checkbox"/> |
| <b>2. PROJECT INFORMATION:</b>  |                  |  |   |  |
| School District/Owner: SAN DIEGO UNIFIED SCHOOL DISTRICT  |                  |  | DSA File Number: 37 58  |  |
| Project Name/School: TORREY PINES ELEMENTARY SCHOOL - HVAC 2000 ES  |                  |  | DSA Application Number 04 115961  |  |
| <b>3. APPLICANT INFORMATION:</b>  |                  |  |   |  |
| Date Submitted: 06/11/20  |                  | Attached Pages? No <input type="checkbox"/> Yes <input checked="" type="checkbox"/> Number of pages? 1 |   |  |
| Firm Name: STUDIO WC ARCHITECTURE & ENGINEERING   |                  | Contact Name: ROBERT WEBB  |   |  |
| Work Email: BWEBB@STUDIOWC.NET  |                  | Work Phone: (760) 753-6800   |   |  |
| Firm Address: 515 ENCINITAS BOULEVARD, SUITE 201  |                  | City: ENCINITAS  | State: CA   | Zip Code: 92024  |
| <b>4. REASON FOR SUBMITTAL: (Check applicable boxes)</b>  |                  |  |   |  |
| For revision or addendum prior to construction.   |                  |  | <input checked="" type="checkbox"/> For a project currently under construction. |  |
| For a project that has a form <i>DSA 301-N: Notification of Requirement for Certification, DSA 301-P: Posted Notification of Requirement for Certification</i> or a 90-Day Letter issued.   |                  |  |   |  |
| To obtain DSA approval of an existing uncertified building or buildings.  |                  |  |   |  |
| For Category B CCD this is: <input type="checkbox"/> a voluntary submittal, <input type="checkbox"/> a DSA required submittal (attach DSA notice requiring submission).   |                  |  |   |  |
| <b>5. DESIGN PROFESSIONAL IN GENERAL RESPONSIBLE CHARGE:</b>  |                  |  |   |  |
| Name of the Design Professional In General Responsible Charge: ROBERT D. WEBB   |                  |  |   |  |
| Professional License Number: C-28036  |                  | Discipline: ARCHITECT  |   |  |
| <b>Design Professional in General Responsible Charge Statement:</b> The attached post-approval documents have been examined by me for design intent and appear to meet the appropriate requirements of Title 24, California Code of Regulations and the project specifications. They are acceptable for incorporation into the construction of the project.   |                  |  |   |  |
| Signature: <u></u><br>DESIGN PROFESSIONAL IN GENERAL RESPONSIBLE CHARGE   |                  |  |   |  |
| <b>6. CONFIRMATION, DESCRIPTION AND LISTING OF DOCUMENTS:</b>   |                  |  |   |  |
| For addenda, revisions, or CCDs: CHECK THIS BOX <input checked="" type="checkbox"/> to confirm that <i>all</i> post-approval documents have been stamped and signed by the Responsible Design Professional listed on form <i>DSA 1: Application for Approval of Plans and Specifications</i> for this project. (For <i>Deferred Submittals</i> , refer to <i>IR A-18: Use of Construction Documents Prepared by Other Professionals</i> , and <i>IR A-19: Design Professional's Signature and Seal (Stamp) on Construction Documents</i> , when applicable, for signature and seal requirements.) |                  |  |   |  |
| Provide a brief description of construction scope for this post-approval document (attach additional sheets if needed):<br>Delete Sheet P0.1's General Note #10. Void General Note #10's requirement to install seismic gas shut off valve. Installation of Site / Building Gas Service and installation of Site Gas Distribution are not in this project's scope of work.  |                  |  |   |  |
| List of DSA-approved drawings affected by this post-approval document:<br>P0.1  |                  |  |   |  |

| DSA USE ONLY |    |      |          |  | Returned    |  | DSA STAMP |          |  |
|--------------|----|------|----------|--|-------------|--|-----------|----------|--|
| SSS          | NL | Date | 06.16.20 | Approved <input checked="" type="checkbox"/> | Disapproved | Not Required                                     | Date:     | 06.16.20 | <div style="border: 2px solid black; border-radius: 15px; padding: 10px; text-align: center;"> APPROVED<br/> DIV. OF THE STATE ARCHITECT<br/> APP.04-115961 INC:<br/> REVIEWED FOR<br/> SS <input checked="" type="checkbox"/> FLS <input checked="" type="checkbox"/> ACS <input type="checkbox"/><br/> DATE: 06/16/2020 </div> |
| Comments:    |    |      |          |  |             |  | By:       | MEM      |  |
| FLS          | RF | Date | 06.12.20 | Approved <input checked="" type="checkbox"/> | Disapproved | Not Required                                     |           |          |  |
| Comments:    |    |      |          |  |             |  |           |          |  |
| ACS          | -- | Date | --       | Approved                                     | Disapproved | Not Required <input checked="" type="checkbox"/> |           |          |  |
| Comments:    |    |      |          |  |             |  |           |          |  |









12515 Woodside Ave, # 996, Lakeside, CA 92040  
[avet@avetcontracting.com](mailto:avet@avetcontracting.com)  
 619-250-6566  
 CA Lic # 981897 License C36

To: **Soltek Pacific**

**7/29/2020**

Attn: **Mark Hofmann**

Job Name: **Package A Torrey Pines**  
 Subject: **Gas Valve Delete CCD 14**  
 Allowance #:  
 Description: **Torrey Pines Seismic Gas Valve Credit**  
**Excludes waterproofing, roofing, patch back and framing**

|                                   |       |              |
|-----------------------------------|-------|--------------|
| Materials and Equipment           | \$389 |              |
| Sales Tax @ 7.75%                 | \$30  |              |
| Tools and Small Equipment Rentals | \$0   |              |
| <b>Subtotal Materials</b>         |       | <b>\$419</b> |
| <b>Subtotal Labor Dollars</b>     |       | <b>\$262</b> |

|                                  |  |              |
|----------------------------------|--|--------------|
| <b>Total Materials and Labor</b> |  | <b>\$681</b> |
| <b>Subtotal Subcontractors</b>   |  | <b>\$0</b>   |

|                                    |          |                 |
|------------------------------------|----------|-----------------|
| <b>Mark-up 15%</b>                 |          | <b>\$102.19</b> |
| <b>TOTAL AVet SELL</b>             |          | <b>\$783</b>    |
| <b>TOTAL AVet SELL (Unit Cost)</b> | <b>1</b> | <b>\$783.47</b> |

**Qualifications:**

This estimate includes cost for labor, materials and equipment necessary to perform the referenced work. Any work not specifically referenced in the attached cost proposal is excluded.

The above referenced cost estimate represents only direct costs related to this change. We reserve the right to submit any additional costs incurred, resulting from the accumulated effect of multiple change orders and the extension of contract time.

Exclusion per contract.

We will proceed with the scope included in this change upon receipt of a confirming Change Order from Soltek.

Quotation is valid for 30 days.

-

Day Extension of Contract Time Required.

**LABOR HOURS / DOLLARS**

|                                    | <b>MANHOURS</b> | <b>\$/MH</b> | <b>COST</b>   |
|------------------------------------|-----------------|--------------|---------------|
| Plumber/Fitter Journeyman:         | 3.06            | 85.71        | 262.19        |
| Plumber/Fitter Journeyman OT:      | 0.00            | 0.00         | 0.00          |
| Plumber/Fitter Foreman:            | 0.00            | 93.62        | 0.00          |
| Plumber/Fitter Foreman OT:         | 0.00            | 0.00         | 0.00          |
| Plumber/Fitter Detailer:           | 0.00            | 93.62        | 0.00          |
| Plumber/Fitter Detailer OT:        | 0.00            | 0.00         | 0.00          |
| Plumber/Fitter General Foreman:    | 0.00            | 99.78        | 0.00          |
| Plumber/Fitter General Foreman OT: | 0.00            | 0.00         | 0.00          |
| Sheet Metal Journeyman:            | 0.00            | 74.83        | 0.00          |
| Sheet Metal Journeyman OT:         | 0.00            | 0.00         | 0.00          |
| Sheet Metal Foreman:               | 0.00            | 78.22        | 0.00          |
| Sheet Metal Foreman OT:            | 0.00            | 0.00         | 0.00          |
| Sheet Metal Detailer:              | 0.00            | 78.22        | 0.00          |
| Sheet Metal Detailer OT:           | 0.00            | 0.00         | 0.00          |
| Sheetmetal General Foreman:        | 0.00            | 80.70        | 0.00          |
| Startup / Training                 | 0.00            | 93.62        | 0.00          |
| <b>TOTAL LABOR DOLLARS</b>         |                 |              | <b>262.19</b> |

**TOOLS AND SMALL EQUIPMENT RENTALS**

|  | <b>QUANTITY</b> | <b>UNIT \$</b> | <b>COST</b> |
|--|-----------------|----------------|-------------|
| Small Tools & Consumables                    |                 |                | 0.00        |
| Scissor lift                                 | 0               | 1200           | 0.00        |
| Fork lift                                    | 0               | 200            | 0.00        |
| Wacker                                       | 0               | 0              | 0.00        |
| Welder                                       | 0               | 0              | 0.00        |
|  | 0               | 0              | 0.00        |
| <b>TOTAL TOOLS &amp; SMALL EQUIP RENTALS</b> |                 |                | <b>0.00</b> |

**SUBCONTRACTS**

|                           |  |  | <b>COST</b> |
|---------------------------|--|--|-------------|
| Insulation                |  |  | 0.00        |
| Firestopping              |  |  | 0.00        |
| Test & Balance            |  |  | 0.00        |
| Temperature Controls      |  |  | 0.00        |
| Rigging                   |  |  | 0.00        |
|                           |  |  | 0.00        |
| <b>TOTAL SUBCONTRACTS</b> |  |  | <b>0.00</b> |



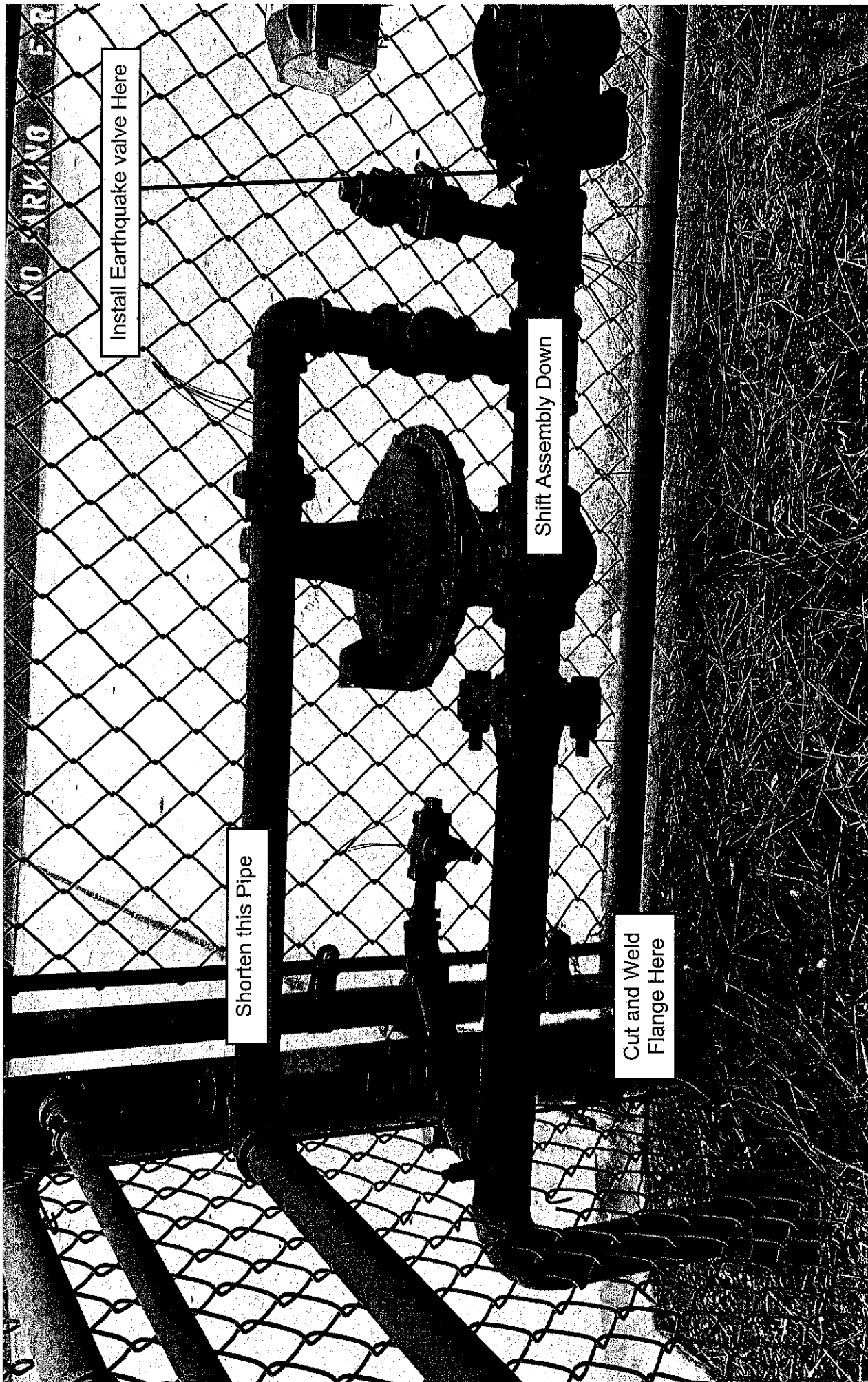

NO PARKING

Install Earthquake valve Here

Shorten this Pipe

Shift Assembly Down

Cut and Weld Flange Here

# A-VET CONTRACTING INC

Project: SDUSD DB Package A, B & C ...  
Trade/Union: Plumbers and Fitters DC16  
Labor rates thru: 08/31/20

## Summary

| Classification  | Regular | Overtime | Doubletime |
|-----------------|---------|----------|------------|
| Journeyman      | 85.71   | 114.44   | 141.36     |
| Foreman         | 94.61   | 127.56   | 158.51     |
| General Foreman | 100.64  | 136.29   | 169.94     |
| Apprentice      | 68.19   | 91.37    | 112.90     |



FERGUSON ENTERPRISES, LLC #667  
 3280 MARKET STREET  
 SAN DIEGO, CA 92102

Phone: 619-515-0300  
 Fax: 619-239-4727

|  |
|--|
| Deliver To:<br>From: Bryan Oliver<br>Comments: |
|--|

18:20:18 JUL 28 2020

Page 1 of 1

FERGUSON ENTERPRISES LLC #1350  
 Price Quotation  
 Phone: 619-515-0300  
 Fax: 619-239-4727

**Bid No:** B138631  
**Bid Date:** 07/28/20  
**Quoted By:** BRO

**Cust Phone:** 858-565-4131  
**Terms:** 2% 10TH NET 30TH

**Customer:** A O REED & CO  
 PO BOX 85226  
 SAN DIEGO, CA 92186-5226

**Ship To:** A O REED & CO  
 PO BOX 85226  
 SAN DIEGO, CA 92186-5226

**Cust PO#:** AVET DESIGN BUILD

**Job Name:**

| Item                   | Description                        | Quantity | Net Price | UM | Total  |
|------------------------|------------------------------------|----------|-----------|----|--------|
| PS314                  | 2" VALVE<br>2 60 PSI NPT QUAKE VLV | 1        | 332.750   | EA | 332.75 |
| 2 DAY LEAD FROM NORCAL |                                    |          |           |    |        |

Quoted prices are based upon receipt of the total quantity for immediate shipment (48 hours). SHIPMENTS BEYOND 48 HOURS SHALL BE AT THE PRICE IN EFFECT AT TIME OF SHIPMENT UNLESS NOTED OTHERWISE. QUOTES FOR PRODUCTS SHIPPED FOR RESALE ARE NOT FIRM UNLESS NOTED OTHERWISE.

CONTACT YOUR SALES REPRESENTATIVE IMMEDIATELY FOR ASSISTANCE WITH DBE/MBE/WBE/SMALL BUSINESS REQUIREMENTS.

Seller not responsible for delays, lack of product or increase of pricing due to causes beyond our control, and/or based upon Local, State and Federal laws governing type of products that can be sold or put into commerce. This Quote is offered contingent upon the Buyer's acceptance of Seller's terms and conditions, which are incorporated by reference and found either following this document, or on the web at <https://www.ferguson.com/content/website-info/terms-of-sale>  
 Govt Buyers: All items are open market unless noted otherwise.

LEAD LAW WARNING: It is illegal to install products that are not "lead free" in accordance with US Federal or other applicable law in potable water systems anticipated for human consumption. Products with \*NP in the description are NOT lead free and can only be installed in non-potable applications. Buyer is solely responsible for product selection.  
 WATER FLOW RATE NOTICE: Lavatory Faucets with flow rates over 0.5 GPM are not allowed for 'public use' in California.



**HOW ARE WE DOING? WE WANT YOUR FEEDBACK!**

Scan the QR code or use the link below to complete a survey about your bids:

<https://survey.medallia.com/?bidsorder&fc=667&on=1000820>

# Specifications: Model 314(60) NPT Valve

## Horizontal Flow

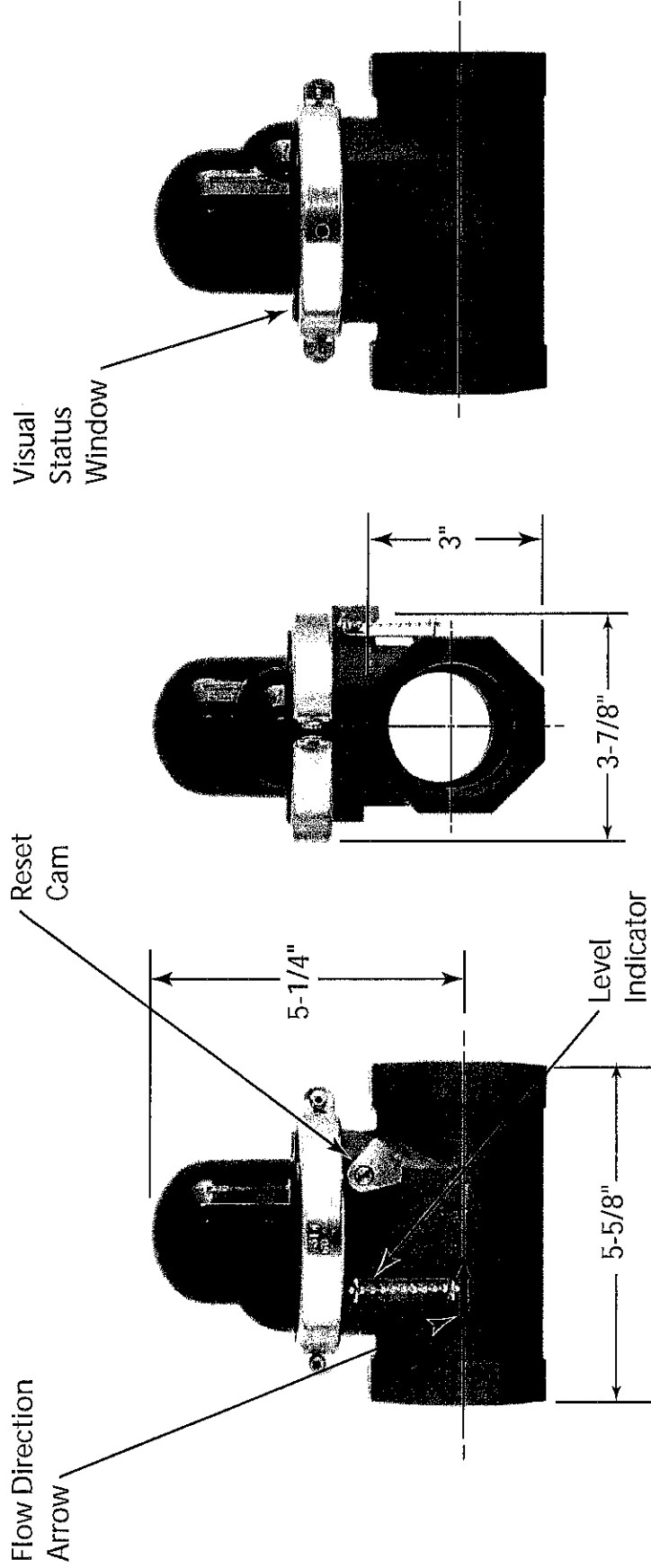

| Valve Model# | CA-DSA No. | Length | Height | Octagon | Nominal Pipe Size | Threads Per Inch | APPLICATION DATA |              |
|--------------|------------|--------|--------|---------|-------------------|------------------|------------------|--------------|
|              |            |        |        |         |                   |                  | Max. Pressure    | Fuel         |
| 314          | 45R-113R   | 5-5/8" | 5-1/4" | 3-7/8"  | 2"                | 11-1/2           | 60 psi           | Dry Fuel Gas |

California Seismic Valves are UL listed in the USA and Canada, Certified by the California State Architect's Office, Approved by the City of Los Angeles, and are warranted free of manufacturer's defects for 30 years. All valves meet California Standards for Earthquake Actuated Automatic Gas Shut off Systems, Standard No. 12-23-1, ANSI Z21.70, 1981 and ASCE 25-97 Standards.

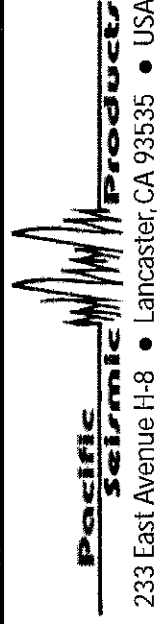

Tel (661) 942-4499  
 Fax (661) 942-0999  
 TF (800) 4-GAS-OFF  
 www.4GasOff.net

